

WBA-24/25-SS2

WORLD BILL ACCEPTOR

SPECIFICATIONS

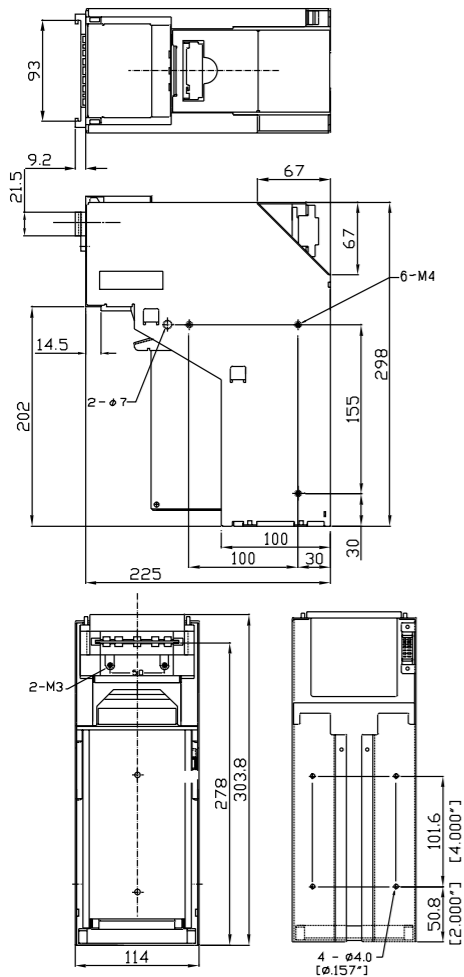

POWER REQUIREMENTS

DC+12V (±5%)
Standby-3VA, Operating-20VA (Max 30VA)

WEIGHT

Approximately 5kg including cashbox

DIMENSIONS

114mm (w) x 225mm (d) x 304mm (h)

HOPPER CAPACITY

Approximately 500 notes (1000 notes Option)

INSERTION

Lengthwise,
Width range is 62-82mm

INFORMATION FOR INSTALLATION

Internal use only, horizontal mounting

VALIDATION SPEED

Validation approximately 2 seconds
Stack completion approximately 5 seconds

ESCROW

One note

MAINTENANCE

All major areas including the bill path are accessible without the use of tools

INTERFACE

Serial interface (photocoupler isolation)/
RS-232C (Option)/MDB (Option)

APPROVALS

CE

ENVIRONMENT

Operating: 5°C-50°C
Storage: -20°C-60°C
Humidity: 30%-85% RH
(no condensation)

SECURITY

EFFICIENCY

QUALITY



WBA-24/25-SS2

WORLD BILL ACCEPTOR



All references in mm



JAPAN CASH MACHINE

EUROPE:

Büttgenbachstraße 5, D-40549 Düsseldorf, Germany
Tel.: +49 211 530 6450 Fax: +49 211 530 64565
Internet: www.jcm-germany.com
e-mail: info@jcm-germany.com

USA:

925 Pilot Road Las Vegas, Nevada 89119
Tel: +1-702 651 0000 Fax: +1-702 644 5512
Internet: www.jcm-american.com
email: sales@jcm-american.com

JCM reserves the right to change product specifications without notice.



www.jcm-germany.com

WHO IS JCM?

- INTRODUCED BILL ACCEPTORS TO THE GAMING INDUSTRY IN 1985
- ONE OF THE LARGEST BILL ACCEPTOR SUPPLIERS IN THE GAMING INDUSTRY
- MANUFACTURER AND DISTRIBUTOR OF CASH HANDLING EQUIPMENT INCLUDING THE WBA™, WORLD BILL ACCEPTOR, WIDELY RECOGNIZED AS AN INDUSTRY STANDARD
- PARENT COMPANY, JAPAN CASH MACHINE, IS LOCATED IN JAPAN WITH INTERNATIONAL SALES OFFICES IN HONG KONG, AUSTRALIA AND SOUTH-AFRICA
- EUROPEAN SUBSIDIARY LOCATED IN GERMANY, DÜSSELDORF
- U.S. SUBSIDIARY LOCATED IN LAS VEGAS, NEVADA, WITH SALES OFFICES IN NEW JERSEY AND MISSISSIPPI

WBA-24/25-SS2

WORLD BILL ACCEPTOR

JCM introduces the WBA-24/25-SS2, specially designed to accept the wider Euro Currency (up to 82mm).

SECURITY

The WBA uses five types of sensing technology, including optical and magnetic, which detect counterfeits for maximum security.



EFFICIENCY

The WBA-24/25-SS2 provides the highest acceptance rate relative to other bill acceptors in the industry. The rate may vary due to bank note quality.

QUALITY

The WBA-24/25-SS2 is manufactured with the same quality standards as all the JCM superior products.

SPEED

The WBA-24/25-SS2 acceptor provides fast validation speed. The notes are stacked in approximately five seconds.



THE WORLD'S CASH HANDLING SOLUTION

CONTACT JCM TODAY!

+49 211 530 6450



UNIQUE

The WBA-24/25-SS2 acceptor-, transportation- unit and cashbox are engineered to be wider to specifically accommodate the Euro currency, while maintaining the standard frame size. The WBA-24/25-SS2 uses new gray parts to distinguish the SS2 from other WBA models.

